

ECHELLE 1 : 2

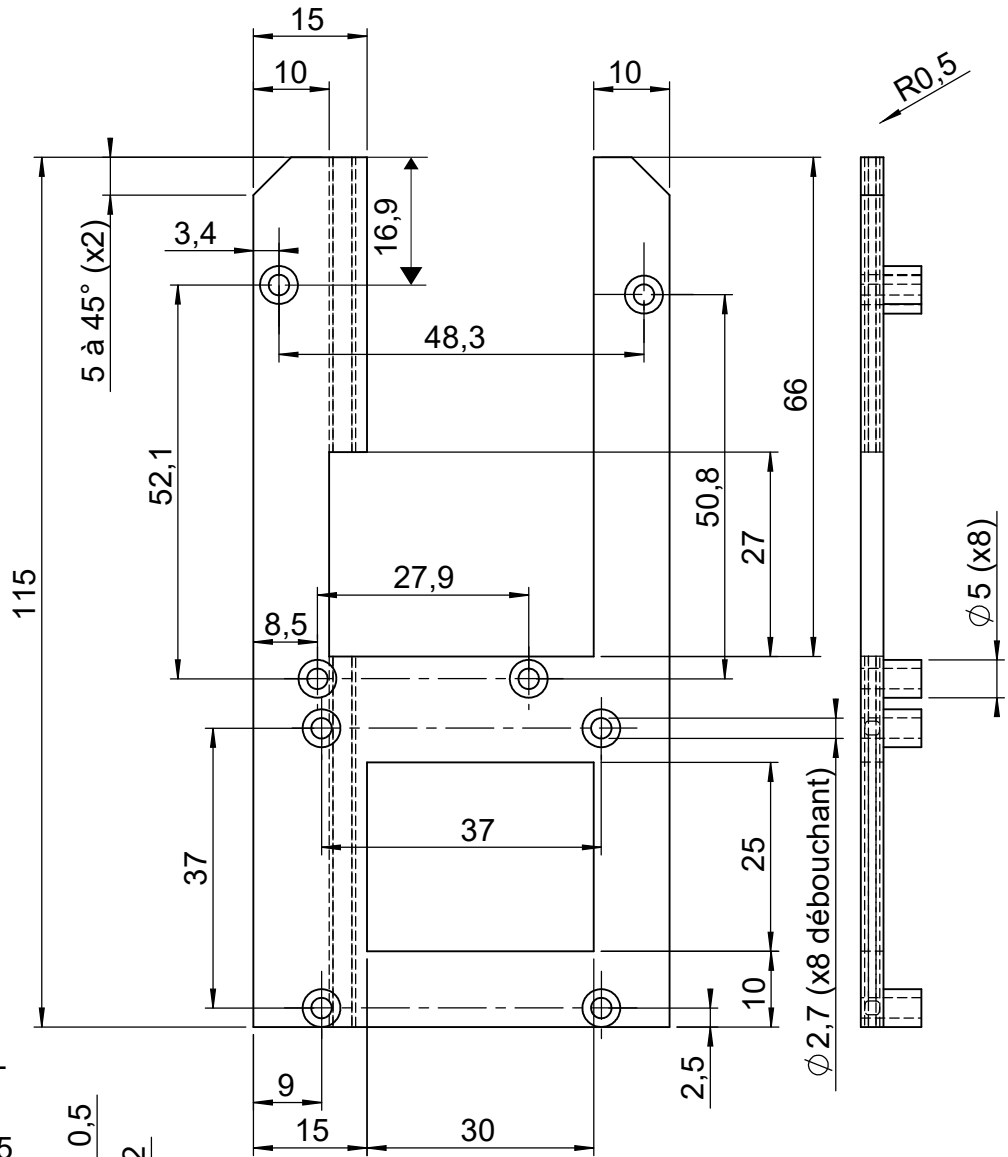

VUE DE DÉTAIL

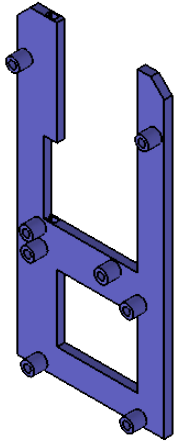
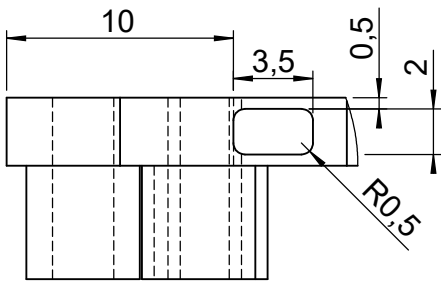

J (3 : 1)

Tolérance Générale : Norme ISO 2768-f sauf indications

| | | | | |
|-----|----|--------------------|---------|-------------|
| 4 | 1 | CHÂSSIS - MODULE 4 | PLA | IMPRIMÉ |
| REP | NB | DESIGNATION | MATIERE | OBSERVATION |

ECHELLE :
1 : 1

ROBOT SUIVEUR DE LIGNE



Baccalauréat Professionnel
Microtechniques

Nom du fichier : Module 4.sldrw

DOC 5/7